



30-6-FL

DOROT model "FL" is an automatic, pilot controlled, level control valve, activated by the pressure of the pipeline.

The valve is mounted on the tank or reservoir inlet, below or above the requested water level.

The float pilot can either be assembled on the main valve, (for above-level installation) or can be connected to the main valve by a command tube.

The valve closes when the water level rises, thus raising the float to its closed position. It opens when the float descends due to a drop in water level. The difference between maximum and minimum levels is very small and is affected by the length of the float pilot arm. In practice, the water level is maintained continuously at the maximum point as long as the upstream flow exceeds the downstream flow.

The main valve is supplied in two models:

**Model 30, 30A** for medium pressure (up to 16 bar / 230 psi)

**Model 31, 31A** for high pressure (up to 25 bar / 350 psi).

For further information see p. G5; and graph #2 on page G5-b.

For pilot data refer to p. G6-e.

### Typical Application:

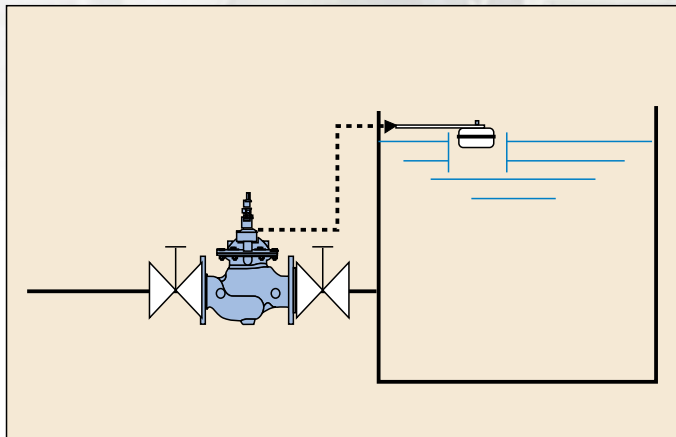

The "FL" Valve, located below water level, prevents overflow and return flow. The pilot float valve is connected to the main valve by a command tube.

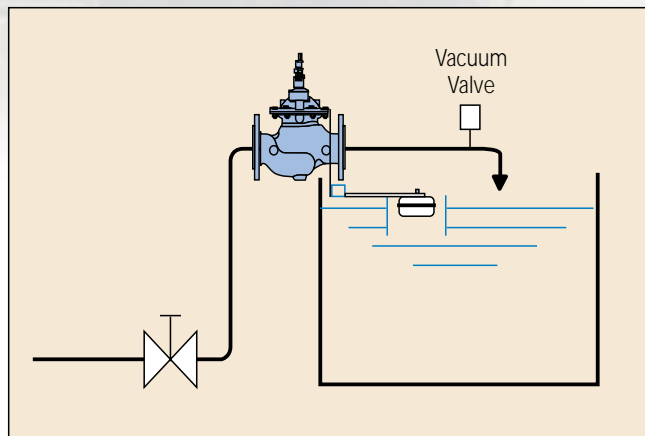

The "FL" Valve, located on top of the tank, prevents overflow.

## Schematic Control Diagram

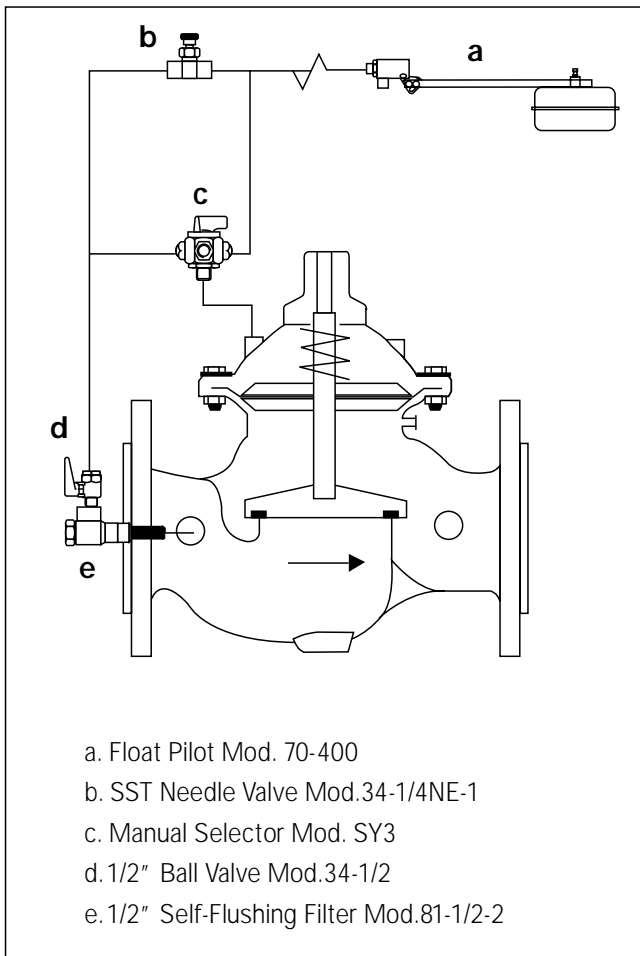

## Purchase Specifications

*(Insert value)*

- The valve will be controlled by a float-operated pilot valve, located in the tank.
- The main valve will be installed below the water level or on top of the tank.
- The valve will be a hydraulically operated, diaphragm actuated, Globe Type.
- The main valve will consist of a removable SST seat and resilient Rubber seal fully supported by a seal disc.
- The stem will be guided at the top by a replaceable guide bearing in the valve bonnet, and at the bottom, by a Bronze centering device, connected to the seal disc and moving freely inside the seat.
- No bottom guide bearing is permitted.
- The diaphragm will be fully supported, top and bottom, by rigid discs and will be connected to the stem in a way which enables fast and easy replacement on site.
- No external packing gland and piston activation is permitted.
- Face-to-face length dimension meets ISO 5752(S-1) Standard.
- Flange standard will be to *(network standard)*.

The control system will consist of:

- 2-Way Float Valve
- SST Needle Valve
- Manual Closure Valve
- Self-Flushing, Removable, Internal Filter.

The valve shall be DOROT mod. 30 (31) - *(size)* - FL or equal in all aspects.

## Design Notes

The float must be surrounded by a partition wall, creating a still water surface.

## Optional Features

Electric On-Off Control *(add code "EL")*.

When ordering specify "normally open" (N.O.) or "normally closed" (N.C).  
 See p. 1A-1 for further information.

Hydraulic Check Valve Function *(add code "CV")*.

See p. 1B-1 for further information.

Back Pressure Sustaining *(add code "PS")*.

See p. 3A-1 for further information.

## Operating Data Checklist

*(Please fill out and send to the distributor when ordering)*

Maximum Flow Rate: \_\_\_\_\_

Maximum Upstream Pressure: \_\_\_\_\_

## How To Order

Please specify the requested valve in the following sequence (see example below):

| Model                     | Size                 | Connection Standard    | Control Function | Additional Features     | Special Instructions |
|---------------------------|----------------------|------------------------|------------------|-------------------------|----------------------|
| 30, 30A<br>31, 31A<br>[D] | (Inch): 1 1/2" - 20" | ISO, ANSI,<br>JIS etc. |                  | Electric On-Off Control |                      |
| ↓                         | ↓                    | ↓                      | ↓                | ↓                       | ↓                    |
| 30                        | — 6                  | — ISO PN16             | — FL             | / EL (N.O.)             | — Position Indicator |